

M1BEM/NC

Kuleventil utv. sveis pneumatisk (NC)

- PP-kuleventil
- PE krager utv. sveis
- Pneumatisk normalt stengt (NC)
- Fast sete, en side av ventilen kan demonteres under fullt trykk.
- PN 10
- EPDM
- Max 80°C
- Tilkobling styreluft: G1/4" Namur
- Styretrykk: 5,5-8 Bar
- Optisk indikering

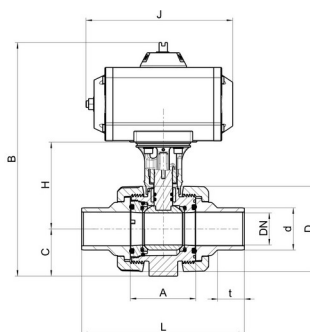

Artikkelnr	d	DN	A	B	C	D	H	J	L	t
M1BEM/NC-E-020	20	15	61.5	202	33	58	80	144	237.5	64
M1BEM/NC-E-025	25	20	69	215.5	40	68.5	85.5	144	241	64
M1BEM/NC-E-032	32	25	73	220	43.5	75.5	88	144	251	61
M1BEM/NC-E-040	40	32	83	250	51	92	97	157	283	65
M1BEM/NC-E-050	50	40	94	261	56.5	108	103	157	296	69
M1BEM/NC-E-063	63	50	109	275.5	64.5	127.5	109.5	157	353	78
M1BEM/NC-E-075	75	65	131.5	350	85	160	151.5	230	381.5	86
M1BEM/NC-E-090	90	80	156.5	376	100	196.5	167	230	436.5	101
M1BEM/NC-E-110	110	80	156.5	376	100	196.5	167	230	474.5	115
M1BEM/NC-V-020	20	15	61.5	202	33	58	80	144	237.5	64
M1BEM/NC-V-025	25	20	69	215.5	40	68.5	85.5	144	241	64
M1BEM/NC-V-032	32	25	73	220	43.5	75.5	88	144	251	61
M1BEM/NC-V-040	40	32	83	250	51	92	97	157	283	65
M1BEM/NC-V-050	50	40	94	261	56.5	108	103	157	296	69
M1BEM/NC-V-063	63	50	109	275.5	64.5	127.5	109.5	157	353	78
M1BEM/NC-V-075	75	65	131.5	350	85	160	151.5	230	381.5	86
M1BEM/NC-V-090	90	80	156.5	376	100	196.5	167	230	436.5	101
M1BEM/NC-V-110	110	80	156.5	376	100	196.5	167	230	474.5	115

Med forbehold om konstruksjonsendringer og tekniske endringer. Kan endres uten varsel.

gpa.no | info@gpa.no | +47 64 85 68 00